

LU10b

REZ DE CHAUSSÉE	
01. DISTRIBUTEUR	5.88 m ²
02. CHAMBRE 1	11.62 m ²
03. SALLE DE BAIN 1	4.40 m ²
04. SÉJOUR - SALON - CUISINE	40.29 m ²
TOTAL Sur. utile plancher	63.40 m²
TOTAL Sur. const. logement	82.38 m²
PREMIERE ÉTAGE	
05. DISTRIBUTEUR	7.18 m ²
06. CHAMBRE 2	12.42 m ²
07. CHAMBRE 3	12.42 m ²
08. SALLE DE BAIN 2	5.26 m ²
TOTAL Sur. utile plancher	39.10 m²
TOTAL Sur. const. logement	70.72 m²
REZ DE CHAUSSÉE	
Sur. utile plancher	63.40 m ²
Sur. const.	82.38 m ²
PREMIERE ÉTAGE	
Sur. utile plancher	39.10 m ²
Sur. const.	70.72 m ²
TOTAL SURFACE	
TOTAL Sur. utile plancher	102.50 m ²
TOTAL Sur. const. logement	153.10 m ²

LU10a

REZ DE CHAUSSÉE	
01. DISTRIBUTEUR	5.88 m ²
02. CHAMBRE 1	11.62 m ²
03. SALLE DE BAIN 1	4.40 m ²
04. SÉJOUR - SALON - CUISINE	40.29 m ²
TOTAL Sur. utile plancher	63.40 m²
TOTAL Sur. const. logement	82.38 m²
PREMIERE ÉTAGE	
05. DISTRIBUTEUR	6.91 m ²
06. CHAMBRE 2	12.42 m ²
07. CHAMBRE 3	12.42 m ²
08. SALLE DE BAIN 2	5.26 m ²
09. CHAMBRE 4	17.21 m ²
10. SALLE DE BAIN 3	5.56 m ²
TOTAL Sur. utile plancher	62.59 m²
TOTAL Sur. const. logement	82.38 m²
REZ DE CHAUSSÉE	
Sur. utile plancher	63.40 m ²
Sur. const.	82.38 m ²
PREMIERE ÉTAGE	
Sur. utile plancher	62.59 m ²
Sur. const.	82.38 m ²
TOTAL SURFACE	
TOTAL Sur. utile plancher	125.99 m ²
TOTAL Sur. const. logement	164.76 m ²

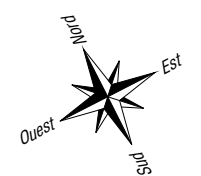

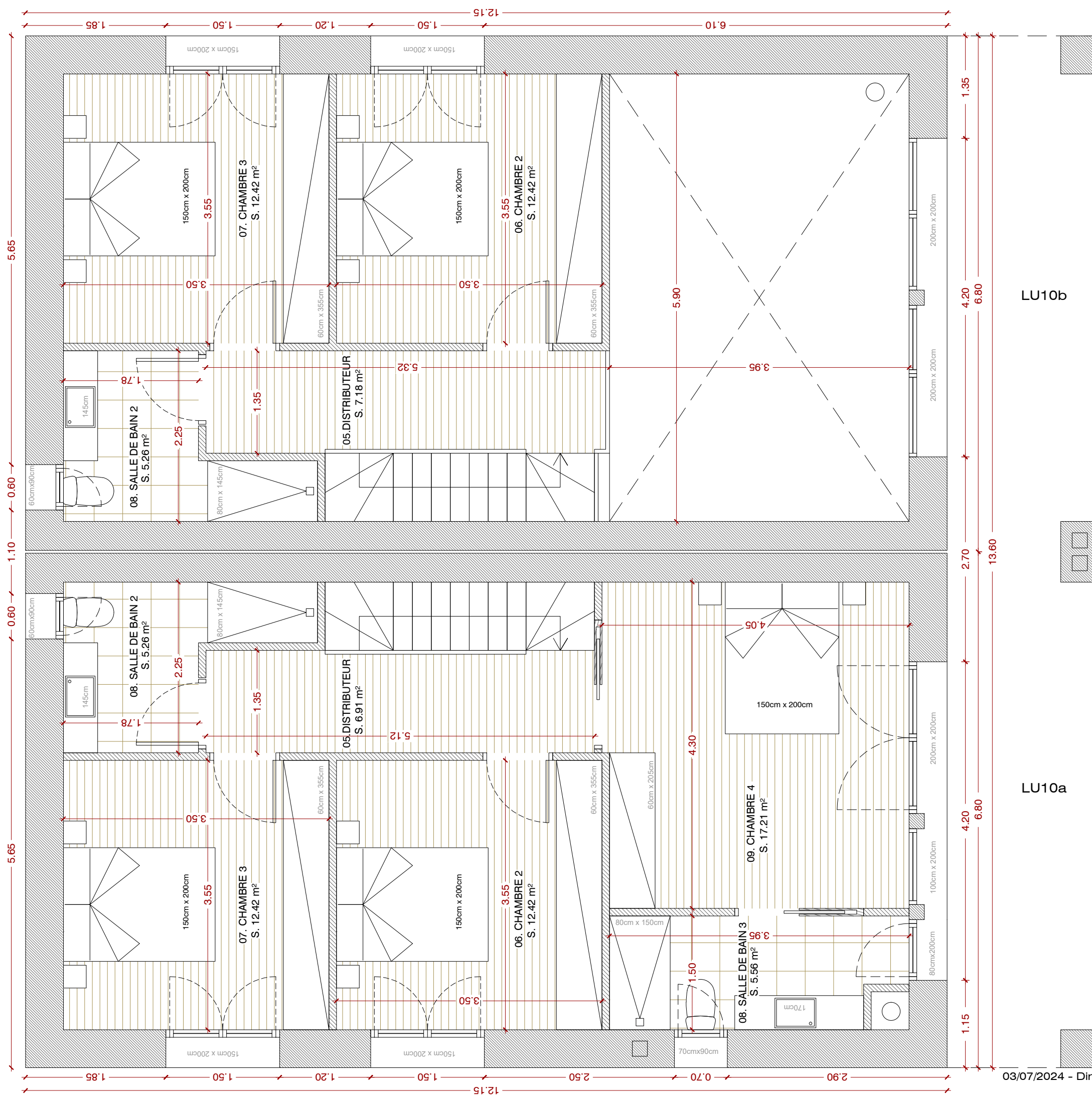

LU10b

REZ DE CHAUSSEE	
01. DISTRIBUTEUR	5.88 m ²
02. CHAMBRE 1	11.62 m ²
03. SALLE DE BAIN 1	4.40 m ²
04. SÉJOUR - SALON - CUISINE	40.29 m ²
TOTAL Sur. utile plancher	63.40 m²
TOTAL Sur. const. logement	82.38 m²
PREMIERE ETAGE	
05. DISTRIBUTEUR	7.18 m ²
06. CHAMBRE 2	12.42 m ²
07. CHAMBRE 3	12.42 m ²
08. SALLE DE BAIN 2	5.26 m ²
TOTAL Sur. utile plancher	39.10 m²
TOTAL Sur. const. logement	70.72 m²
REZ DE CHAUSSEE	
Sur. utile plancher	63.40 m ²
Sur. const.	82.38 m ²
PREMIERE ETAGE	
Sur. utile plancher	39.10 m ²
Sur. const.	70.72 m ²
TOTAL SURFACE	
TOTAL Sur. utile plancher	102.50 m ²
TOTAL Sur. const. logement	153.10 m ²

LU10a

REZ DE CHAUSSEE	
01. DISTRIBUTEUR	5.88 m ²
02. CHAMBRE 1	11.62 m ²
03. SALLE DE BAIN 1	4.40 m ²
04. SÉJOUR - SALON - CUISINE	40.29 m ²
TOTAL Sur. utile plancher	63.40 m²
TOTAL Sur. const. logement	82.38 m²
PREMIERE ETAGE	
05. DISTRIBUTEUR	6.91 m ²
06. CHAMBRE 2	12.42 m ²
07. CHAMBRE 3	12.42 m ²
08. SALLE DE BAIN 2	5.26 m ²
09. CHAMBRE 4	17.21 m ²
10. SALLE DE BAIN 3	5.56 m ²
TOTAL Sur. utile plancher	62.59 m²
TOTAL Sur. const. logement	82.38 m²
REZ DE CHAUSSEE	
Sur. utile plancher	63.40 m ²
Sur. const.	82.38 m ²
PREMIERE ETAGE	
Sur. utile plancher	62.59 m ²
Sur. const.	82.38 m ²
TOTAL SURFACE	
TOTAL Sur. utile plancher	125.99 m ²
TOTAL Sur. const. logement	164.76 m ²

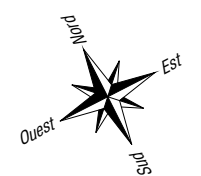

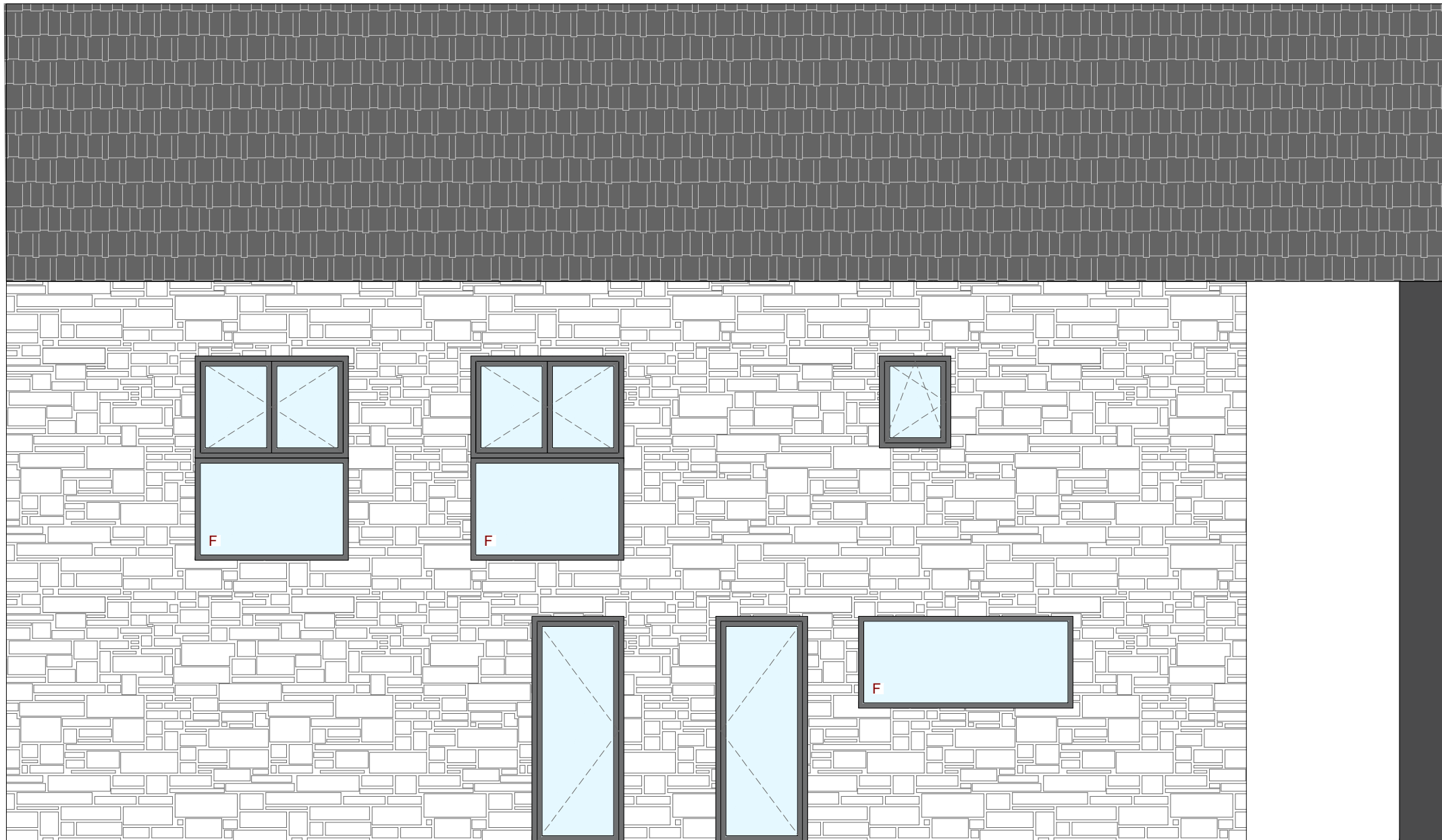

LU10a

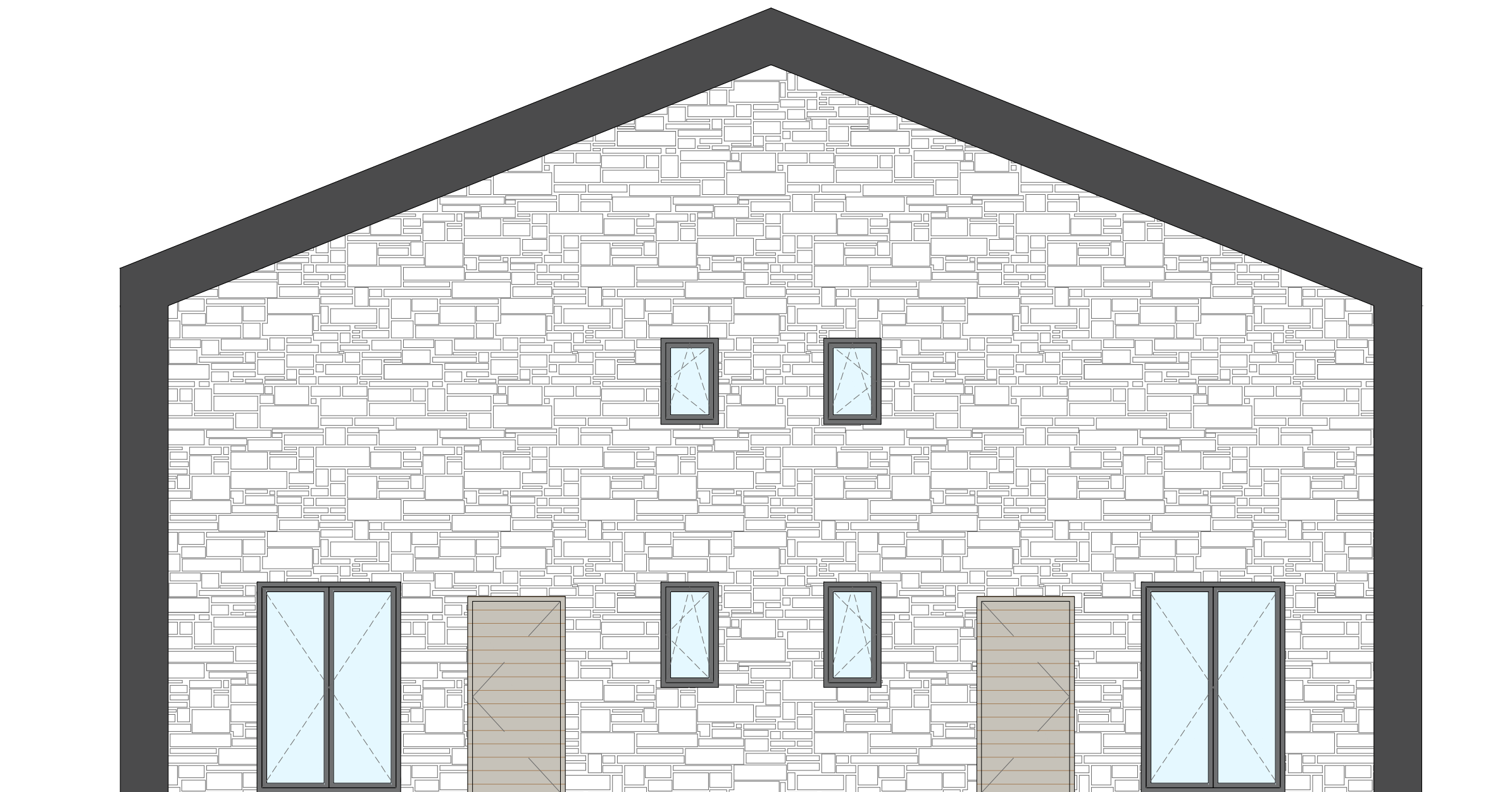

LU10b

LU10a



LU10a

LU10b

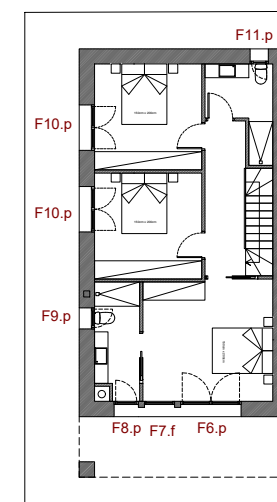
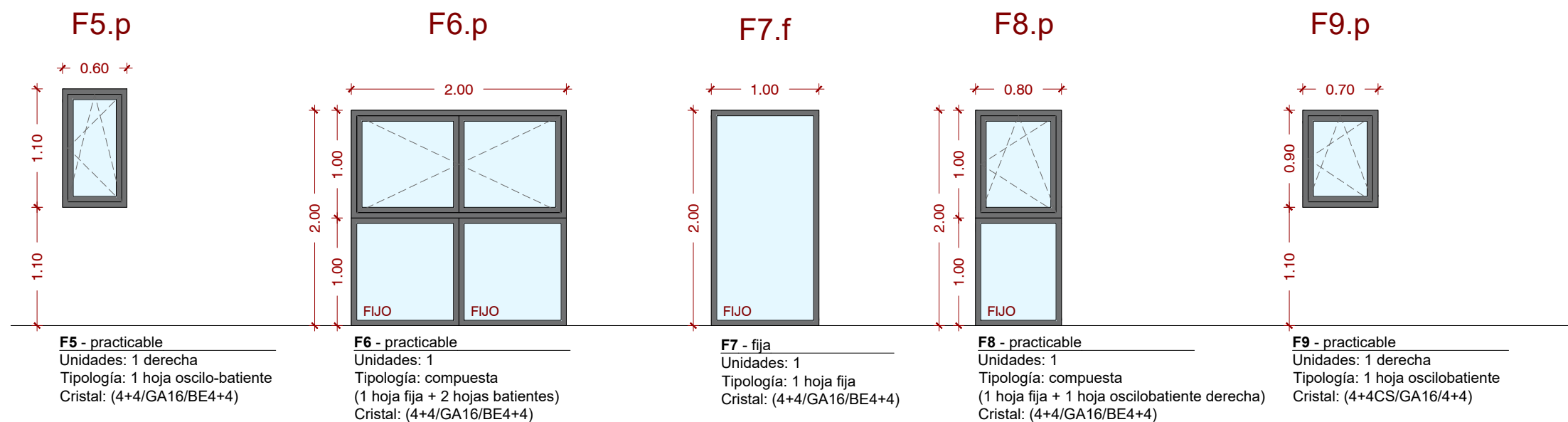
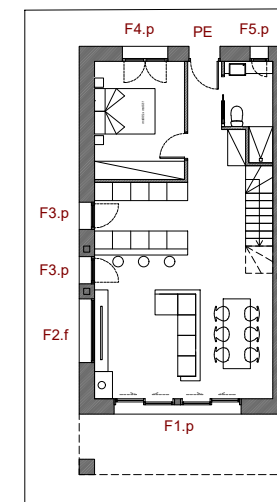
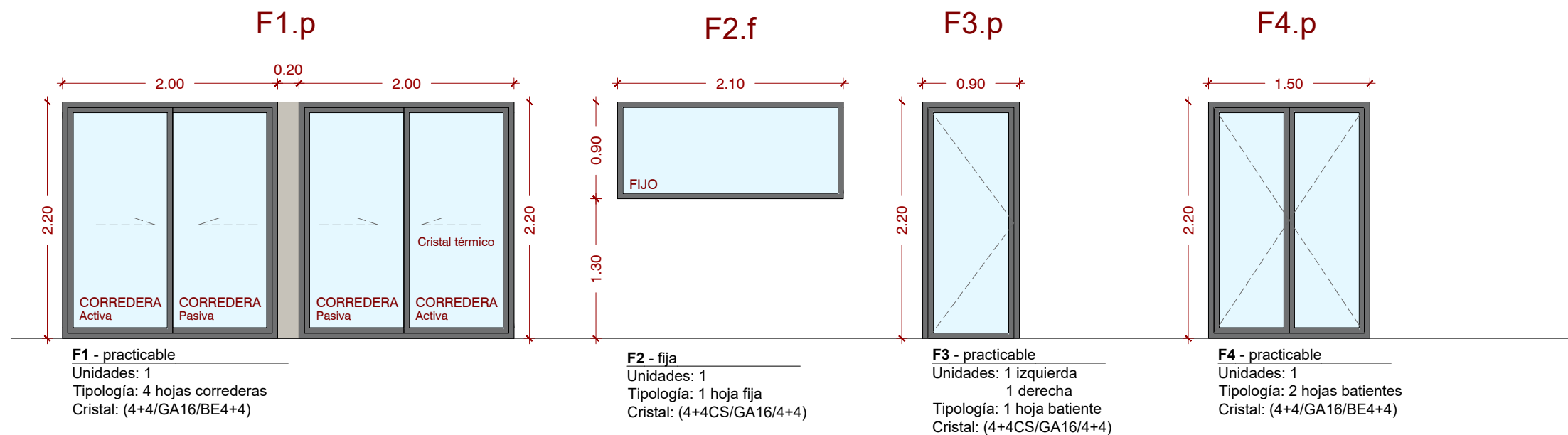

*Vista puertas y ventanas desde el interior.
 Paso libre puerta de entrada 92cm
 Paso libre puertas de paso 82cm
 **Ventanas oscilo-batientes con posición de microventilación.

